

User Guide

Model No.: GDI-BTTV100

gracedigital

Important Safety Instructions and Warnings

Please read before installation

WARNING:

- To reduce the risk of fire or electrical shock, do not expose the product to rain or moisture.
- The product should not be exposed to any dripping or splashing liquid.
- Objects filled with liquids, such as vases, should not be placed on the product.
- No open flame sources, such as lighted candles, should be placed on the product.
- Keep the remote control battery or optional rechargeable battery away from children. It may cause a fire or a chemical burn if mishandled. Do not disassemble, heat above 100°C (212°F), or incinerate. Dispose of used batteries promptly. Replace only with a battery of the correct type and model number.

CAUTION:

1. Please retain these safety instructions for future reference.
2. Please follow these instructions. These instructions contain information for your safety.
3. Please heed the safety warnings on the product and in the user's guide. Failure to do so could result in injury or damage to the product.
4. Power source - the product can only be connected to a power supply of the type specified in the user's guide or as marked on the product. Do NOT use Alkaline batteries or any other rechargeable battery other than the Lithium ion battery designed for use with the product.
5. Power cord protection - protect the power cord from damage. Do not walk on the power cord. Please take care not to let the power cord become pinched, particularly at the plug.
6. Water and moisture - the product should not be used near water (for example, near a bathtub, washbowl, kitchen sink, laundry tub, in a wet basement, or near a swimming pool etc.)
7. Heat - keep the product away from heat sources such as radiators, heat registers, stoves or other appliances that produce heat.
8. Damage requiring service - the product should be serviced by qualified service personnel if:
 - a) The power supply cord or the plug has been damaged: or
 - b) Objects have fallen or liquid has been spilled into the product: or
 - c) The product has been exposed to rain: or
 - d) The product does not appear to operate normally or exhibits a marked performance change:
 - e) Or the product has been dropped, or the enclosure damaged.

13. Servicing - the user should not attempt to service the product. All servicing should be referred to qualified service personnel.
14. Unplug the power adapter during lightning storms or when unused for long periods of time.

ADVISORY

This Product is intended for **North American markets**. The TV Bluetooth wireless speaker (GDI-BTTV100) by Grace Digital is in compliance with the essential requirements and other relevant provisions of Directive 1999/5/EC

ADVISORY

FCC Compliance and Advisory Statement: This device complies with **Part 15** of the **FCC Rules**.

Operation is subject to the following two conditions: 1) this device may not cause harmful interference, and 2) this device must accept any interference received, including interference that may cause undesired operation

NOTE: This equipment has been tested and found to comply with the limits for a Class B digital device, pursuant to **Part 15** of the **FCC Rules**. These limits are designed to provide reasonable protection against harmful interference in a residential installation. This equipment generates uses and can radiate radio frequency energy and, if not installed and used in accordance with the instructions, may cause harmful interference to radio communications. However, there is no guarantee that interference will not occur in a particular installation. If this equipment does cause harmful interference to radio or television reception, which can be determined by turning the equipment off and on, the user is encouraged to try to correct the interference by one or more of the following measures:

To comply with FCC RF exposure compliance requirements, a separation distance of at least 20 cm must be maintained between the antenna of this device and all persons. This device must not be co-located or operating in conjunction with any other antenna or transmitter.”

WARNING

This product may contain chemicals listed in **Proposition 65** (http://www.oehha.ca.gov/prop65/prop65_list/Newlist.html) that may be known to cause cancer, birth defects or other reproductive harm

INSTALLATION GUIDE

Thank you for your purchase of the TV Bluetooth wireless speaker, with built in Grace LIP SYNC software. This guide provides a review of the main functions of the TV Bluetooth wireless speaker as well as an installation guide.

BASIC INSTALLATION

Step 1: Connecting power to your BTTV Transmitter. There are 2 options to provide power to your BTTV transmitter.

- Option 1 is to use the included power adapter. Plug the power adapter into a wall outlet. The other end of the power adapter cable plugs into the connection on the transmitter marked POWER. (When plugged into a wall outlet the transmitter will go into standby automatically when not in use after 10 minutes and turn back on when your TV audio is in use.) **OR**
- Option 2 is to use a USB micro cable (not included). Plug one end of the cable into any USB output jack on the back of your TV. The other end of the cable plugs into the connection on the transmitter marked POWER. (When plugged into your TV's USB connection the BTTV transmitter will power on and off within 5 seconds when your TV is powered on and off.)

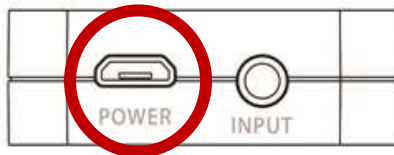

Step 2: Connecting the audio cable to the transmitter and your TV or other audio device (cable box, Satellite box, etc.). There are two options to connect your TV's audio to the BTTV transmitter.

- Option 1 is to use the digital SPDIF audio out connection on your TV. This provides the best audio performance. Use the included SPDIF to 3.5mm cable. Connect the SPDIF side of the cable into your TV's SPDIF connector. The 3.5mm side of the cable plugs into the connector on the transmitter marked **INPUT**. **OR**
- Option 2 is to use the analog audio out connection on your TV. This provides very good audio performance. Use the 3.5mm to 3.5mm cable provided. Connect either side of the cable into your TV's audio output connector and the other side of the cable plugs into the connector on the transmitter marked **INPUT**.

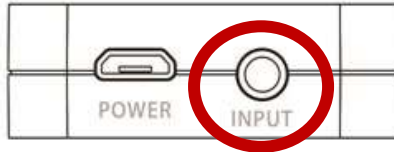

Step 3: Using the provided power adapter. Plug the power adapter cable into the back of the BTTV speaker marked DC IN and the other end into the wall outlet. The unit is now in standby mode and ready to use.

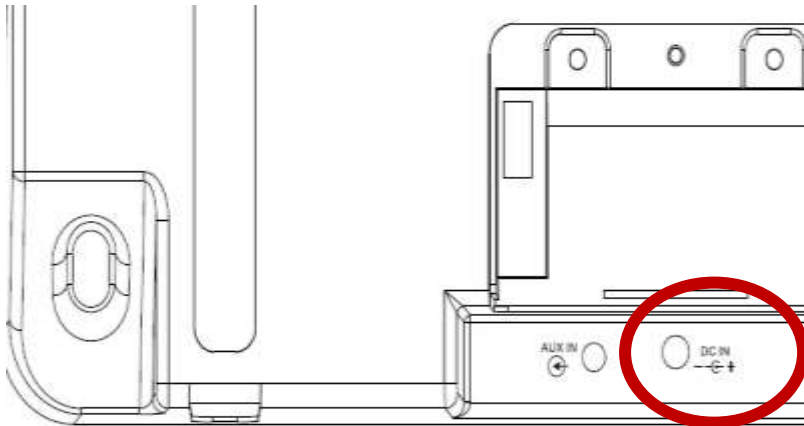

Step 4: Connecting the Transmitter wirelessly to the BTTV Speaker

- A) Turn your TV and TV volume on (do not MUTE your TV audio during set up).
- B) Turn the BTTV speaker on by pressing the power button on top of the speaker. The power LED light behind the speaker grill will turn green when the speaker is on.
- C) Then press the PAIR button on top of the speaker.
- D) Then press the PAIR button on the transmitter.

Both the Bluetooth LED light on the transmitter and the Bluetooth LED light on the speaker will start blinking then they will turn solid blue when they have successfully connected to each other. You can now turn the large volume knob on the speaker to the right or left to adjust your volume.

NOTE: The above steps A - D are **ONLY** required for the 1st time set up. The next time you turn your TV on the transmitter will automatically turn ON and Bluetooth LED will start blinking then when you turn the BTTV speaker ON the transmitter will automatically connect and both Bluetooth lights will turn solid blue and audio will play within 5 seconds. *Always make sure your TV audio is not on MUTE.*

OPTIONS: Most TV's have a settings menu that allow for different type of volume control for extra speakers connected to your TV. Please consult your TV's manual for your TV's various options. In general most TV's have the following options in your TV's setting menu in the AUDIO section:

- 1) **TV speakers ON or OFF.** Most TV's allow you to keep your TV speakers on, or to turn them off so only the Grace BTTV speaker is playing. Many of our customers prefer to turn their TV speakers OFF when using our system but either option will work.
- 2) **Fixed volume.** This is sometimes called LINE out volume. This feature provides a fixed volume level to the Grace speaker. When this is turned on changing the volume on your TV will NOT change the volume on the

Grace Speaker. The only way to change the volume on the Grace speaker when your TV is in FIXED VOLUME mode is with the Grace remote or on the speaker's volume knob.

- 3) **Variable volume:** When you change the volume on your TV the volume on the Grace BTTV speaker will also change when your TV is set to Variable VOLUME mode. This is a good feature if you keep your speakers on your TV on. In this situation you can use the volume knob on the Grace speaker to change the volume level as it relates to the volume level on your TV. Then your TV remote will act as a master volume changing both your TV and Grace speaker volume up or down at the same time.
-



1. **INPUT BUTTON:** Changes the audio source to an optional audio source plugged into the rear of the speaker .
2. **BLUETOOTH BUTTON:** Changes the audio source to your TV
PAIR BUTTON: Pair your speaker to your transmitter that connects to your TV
3. **POWER BUTTON:** Pressing the button turns the TV Bluetooth wireless speaker for tablet ON and OFF

Front view of TV Bluetooth wireless speaker

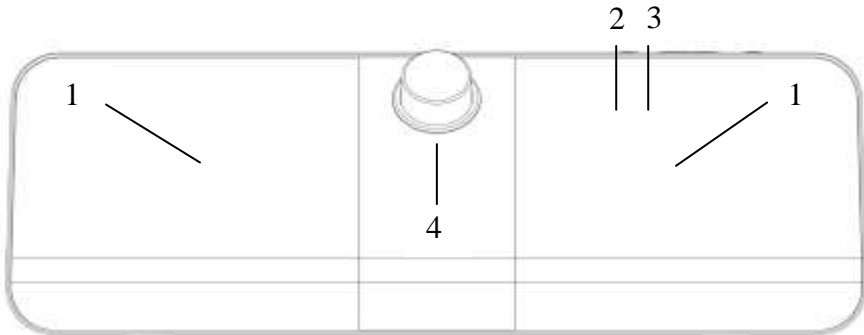

1. STEREO SPEAKERS: 2 - full range stereo speakers
2. LED LIGHT: Power indicator status behind the grill
(see LED status indicator chart)
3. LED LIGHT: Bluetooth indicator status behind the grill
(see LED status indicator chart)
4. Volume / Mute / equalizer: Turn to move volume up or down, briefly press to mute, Press for 2 seconds to change from TV (voice optimized) to music mode. Each 2 second press will toggle between Voice optimized and music optimized mode. All previous settings are remembered when you turn the unit back on.

Back view of TV Bluetooth

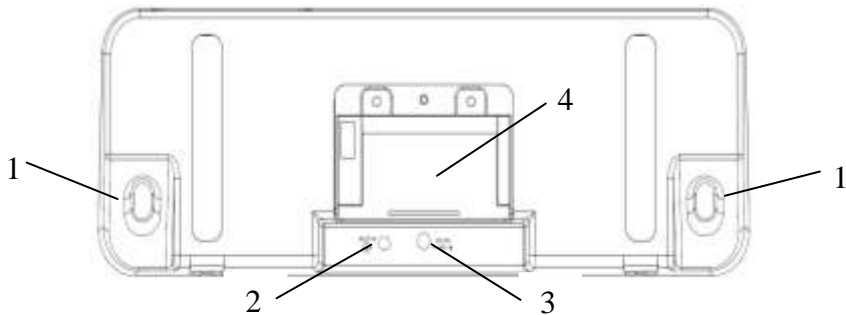

1. **BASS PORTS:** Dual bass ports for extended bass performance of the front mounted stereo speakers.
2. **AUX IN:** Allows you to connect any audio source to play through the TV Bluetooth wireless speaker such as an iPhone, Kindle, CD player etc.
3. **POWER CONNECTOR:** Connect the AC power adapter (included) into the TV Bluetooth wireless speaker and the other end into a wall power outlet.
4. **BATTERY DOOR:** Access the internal battery compartment to install the optional lithium-ion rechargeable battery (sold separately) for up to 6 hours of portable use. Do NOT use Alkaline or alternative rechargeable batteries.

Transmitter Diagram

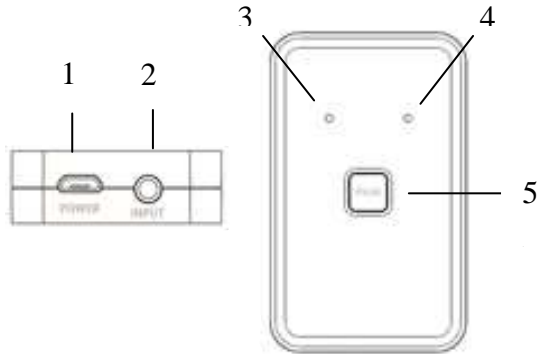

1. Power: Plug into the back of your TV USB jack (cable not included) for power or use separate power supply (included).
2. Audio input: Connect to your TV's audio output jack.
3. LED LIGHT: Bluetooth indicator status
4. LED LIGHT: Power indicator status
5. Pair: Bluetooth pairing button (press this for initial set up to the BTTV speaker. You may also need to press this button if the transmitter ever loses connection to the BTTV speaker.

Remote Control

1. Power button: Turns the TV Bluetooth wireless speaker ON/OFF
2. Mute: Mute ON/OFF
3. Volume: Volume up '+', Volume down '-'
4. Default EQ: Reset to factory equalizer setting
5. Bass: Bass up '+', Bass down '-'
6. Input: toggles between aux in and Bluetooth transmitter audio
7. Treble: Treble up '+', Treble down '-'

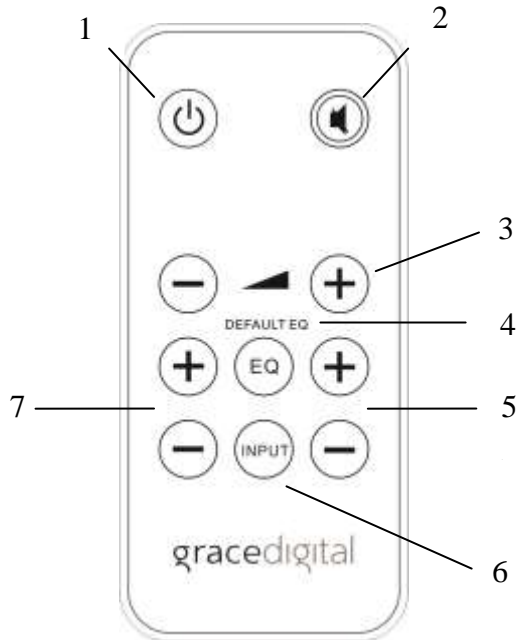

LED Status Indicator

SPEAKER LEDs

LEFT LED

Standby	Steady Orange
Power On	Stead Green
Mute On	Flashing Green
Vol + / Vol -	Flashing Green
Low Battery	LED Flashes every 2 seconds
Battery charging	LED Flashes every 5 seconds

RIGHT LED

Pairing / connecting	Flashing Blue
Connected	Solid Blue

TRANSMITTER LEDs

LEFT LED

Pairing / connecting	Flashing Blue
Connected	Solid Blue
Not Connected	Off

RIGHT LED

Power On	Solid Orange
Power Off	Off

IMPORTANT: Do NOT use Alkaline batteries or any other rechargeable battery other than the **Lithium-ion** battery designed for use with the product. Use the AC power adapter included with the TV Bluetooth wireless speaker.

Specifications

- Class D digital amplifier, 16 watts
- S/N ratio: 89dB
- Frequency response: 60Hz - 18 kHz +/- 3dB
- Channels: 2 (stereo)
- Speaker drivers: 3" Full range x 2
- Dimensions: 13" x 3.8" x 4.3"
- Rechargeable Lithium-ion Battery Pack 7.4V DC, 2200mAh, 2S1P (sold separately)

What's in the box

- TV Bluetooth wireless speaker
- 12 volt UL approved AC power adapter for speaker
- 5 volt UL approved AC power adapter for transmitter
- Remote control and remote control battery
- 2 audio cables: S/PDIF to 3.5mm optical cable for a digital connection and 3.5mm analog cable if you use an analog connection
- User Guide
- Bluetooth transmitter with aptX Lip Sync
- Sold separately: Rechargeable Lithium-Ion Battery (ACC-GFDLI) made for use with the TV Bluetooth wireless speaker

Warranty

Your TV Bluetooth wireless speaker is guaranteed against original defects in materials, manufacture and workmanship for one year from the date of purchase.

Under this warranty, repair of any defect or, at the company's discretion, replacement of the faulty component(s) without charge for parts or labor, is agreed. This warranty does not imply any acceptance by TV Bluetooth wireless speaker, retailers or its agents for consequential loss or damage and specifically excludes fair wear and tear, accident, misuse of unauthorized modification.

This warranty is applicable in the United States only and does not in any way limit the customer's legal rights. Claims and enquiries under the warranty for Grace products purchased outside the USA should be addressed to the local importers or distributors. If you have reason to claim under the warranty please contact your dealer in the first instance. Please retain all original packaging materials for possible future use. We suggest that you complete details of purchase now and keep

this information in a safe place for future reference. Grace Digital provides their Canadian, Central & South American dealers, distributors, and retailers with a 1 year warranty.

- Your **TV Bluetooth wireless speaker** is supported by a limited manufacturer's warranty for product defects in material or workmanship that may be evident under normal use for 1 year from date of purchase from an authorized franchisee or dealer.
- The warranty stated herein is the only warranty applicable to this product. All other warranties, expressed or implied are hereby disclaimed and are limited by the written limited warranties contained herein. Except as provided herein, the manufacturer shall have no liability or responsibility to a customer or any other person or entity with respect to any liability, loss or damage caused directly or indirectly by use or performance of the product or arising out of any breach of this warranty, including, but not limited to, any damages resulting in inconvenience, loss of time, data, property, or profit or any indirect, special, incidental, or consequential damages, even if the manufacturer has been advised of the possibility of such damages.
- In the event of a product defect during the warranty period, return of the product and your sales receipt as proof of purchase date for your **TV Bluetooth wireless speaker** unit is required and shall, at the discretions of the manufacturer, result in: (a) correction of the defect by repair without charge for parts and labor; (b) replacement with the same or similar design; or (c) refund for the purchase price if purchased directly from Grace Digital and returned within 30 days of purchase. All replaced parts and products, and products, on which a refund may be made, become the property of the manufacturer. New or reconditioned parts/ products should be warranted for the remainder of the original warranty period.
- **The warranty does not cover:**
 - (a) damage or failure caused by or attributed to acts of God, abuse, accident, misuse, improper installation or improper maintenance, alteration, lightning or excessive voltage or current;
 - (b) any repairs other than those provided by a **TV Bluetooth wireless speaker** authorized service facility;
 - (c) consumables such as fuses or batteries;
 - (d) cosmetic damage;
 - (e) transportation, shipping or insurance costs;
 - (f) costs of product removal, installation, set-up, service adjustment or re-installation.
- Customers are responsible for any shipping costs related to product return, repair and/or refund.
- Warranty terms may be revised without notification at the discretion of the manufacturer.

Customer Service and Support

Thank you for your purchase. For questions regarding your product please visit us at:

www.gracedigital.com or contact us at: <http://www.gracesupport.com>
